



Rabbit/Chandelle Machine Adjustments Model AR2002

The Rabbit/Chandelle Machine (AR2002) comes with two arms, the **Rabbit Arm (AL554A)** and the **Standard Arm (AL454A)**, both are labeled accordingly. There are two other arms available as well, the **High Angle Rabbit Arm (AL554HAA)** and the **High Angle Chandelle Teal Arm (AL454HA)**. The machine is shipped with the Rabbit Arm (AL554A) already installed. See illustrations below.

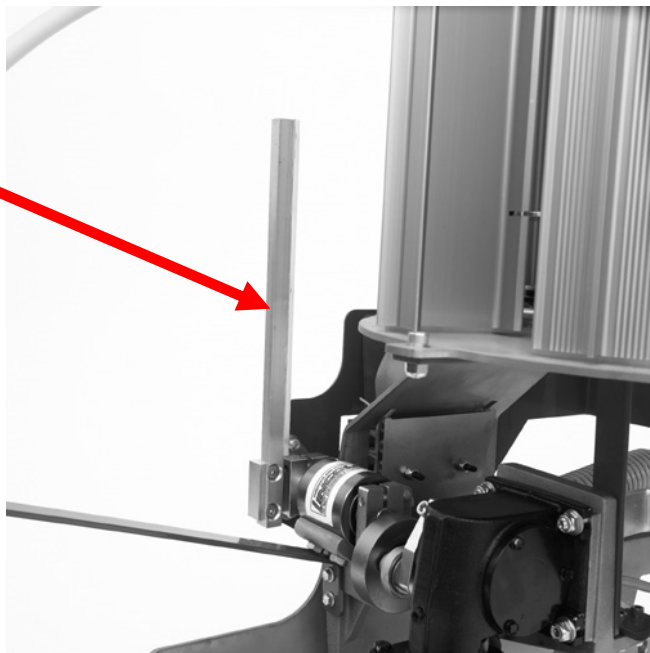

Illustration 1. Rabbit Arm
(Installed on machine)

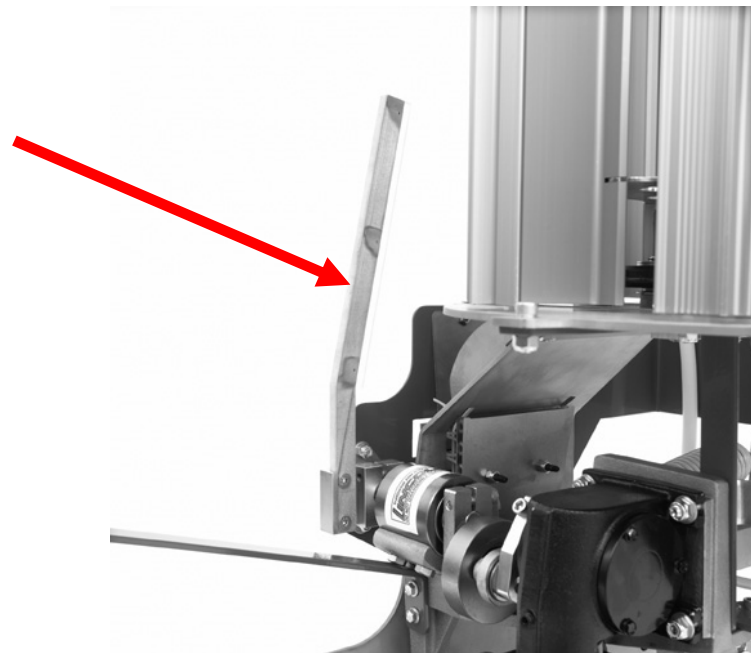

Illustration 2. Standard Arm



Rabbit Machine Adjustments Model AR200218

Before making any adjustments to switch arms please be familiar with the different components of the machine.

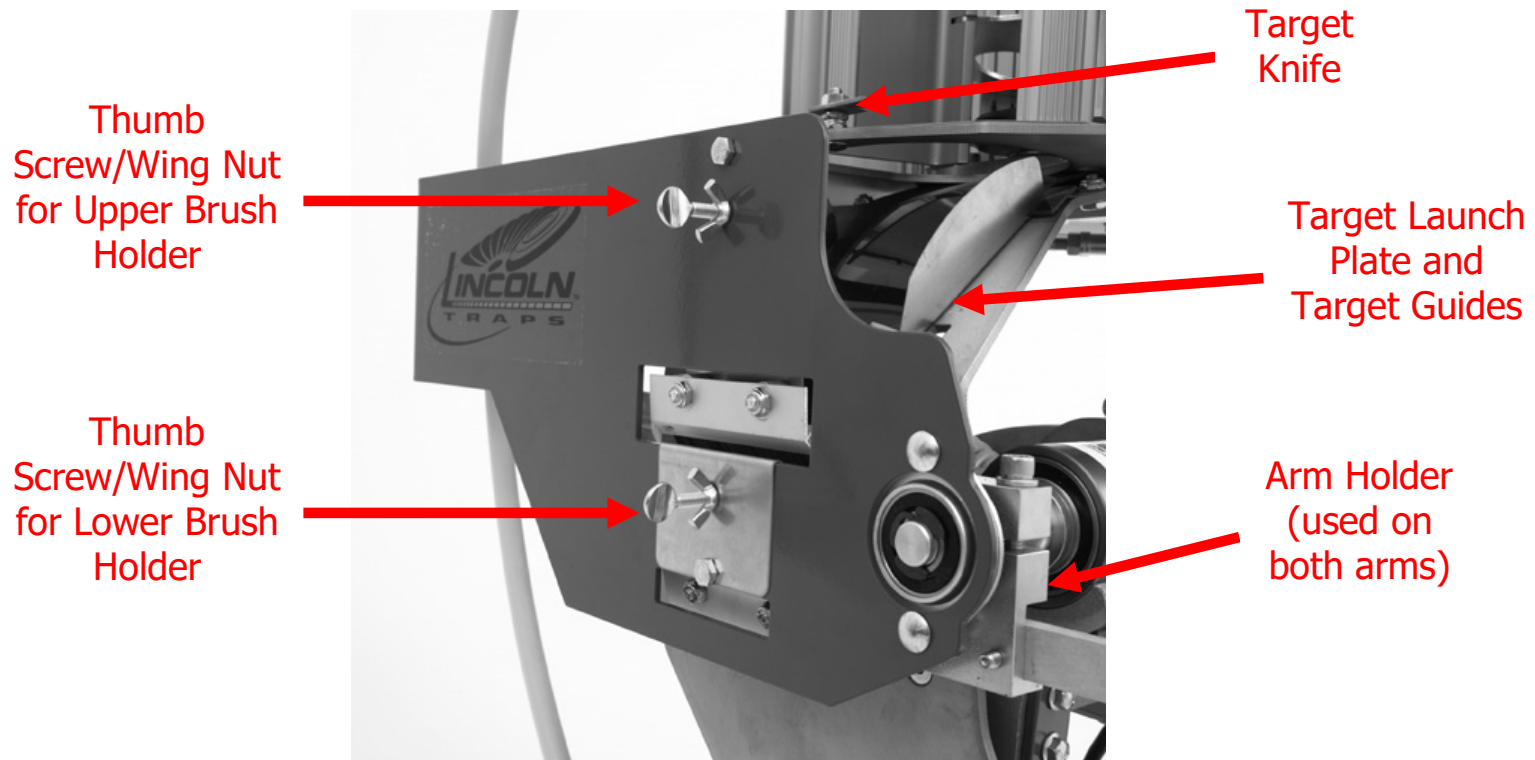
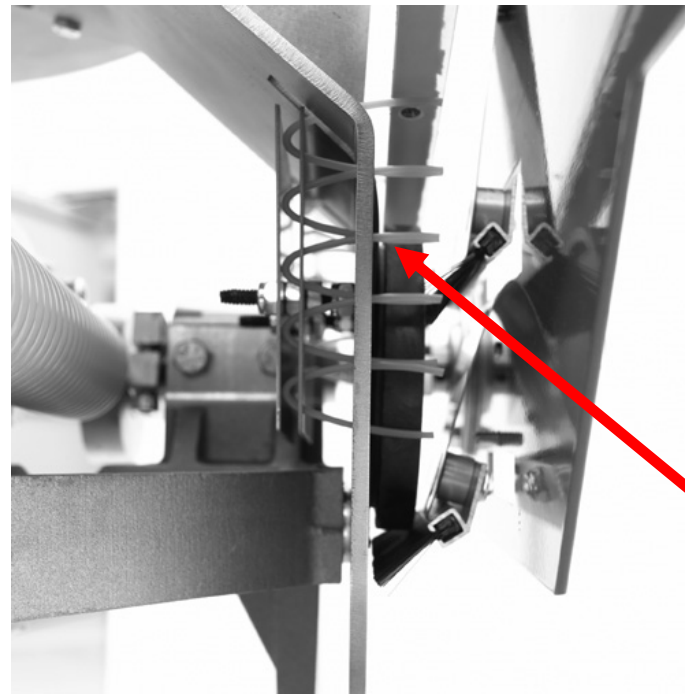

Illustration 3. Machine Components



Rabbit Machine Adjustments Model AR200218

The machine is shipped with the **Rabbit Arm** already installed and it is ready for use with rabbit targets. This arm will enable the machine to throw rabbit presentation targets. Below is an illustration of the feeding process with the **Rabbit Arm**.



The Rabbit Arm makes full contact with the surface of the rabbit target

Illustration 4. Back view



Rabbit Machine Adjustments Model AR200218

Follow these steps to switch arms in order to start throwing standard targets:

1. Make sure the machine is un-cocked, that the spring is completely relaxed, and that the main power supply is disconnected.
2. Remove the **Rabbit Arm** from the **Arm Holder** by removing the two Allen head bolts using a 5/32" Allen wrench.
3. Install the **Standard Arm** and secure it to the **Arm Holder** using hardware provided.
4. The **Standard Arm** should make contact in the middle section of the target as shown.

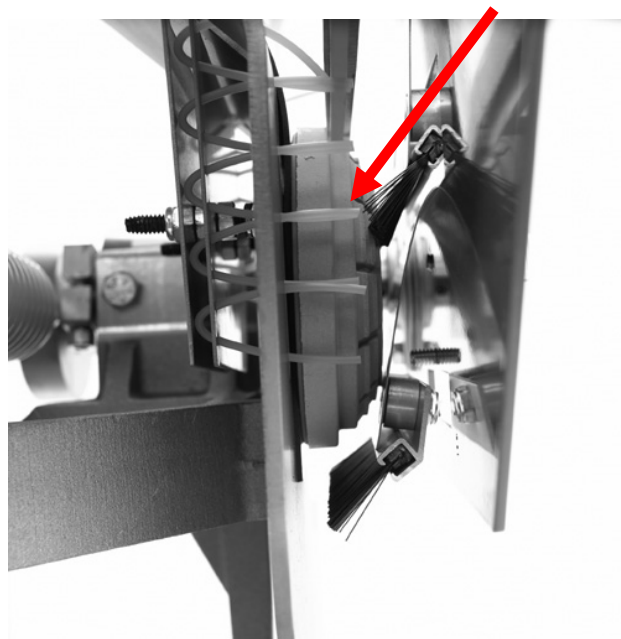

Illustration 5. Back view



Rabbit Machine Adjustments Model AR200218

5. Adjust the **Upper Brush** by backing out the **Upper Thumb Screw**. Make sure to apply just enough pressure with the brush so that the target stops between the brushes and it stays flush to the **Target Launch Plate** as shown on Illustration 5. Secure the position of the **Upper Brush** by tightening its wing nut. Not following these instructions will cause feeding problems and target breakage.
6. Load one silo of the carrousel with about 5-6 standard targets and manually turn the magazine to double-check the position of the **Target Knife**. If necessary make adjustments to the **Target Knife** ensuring it separates the standard targets as shown on Illustration 7.

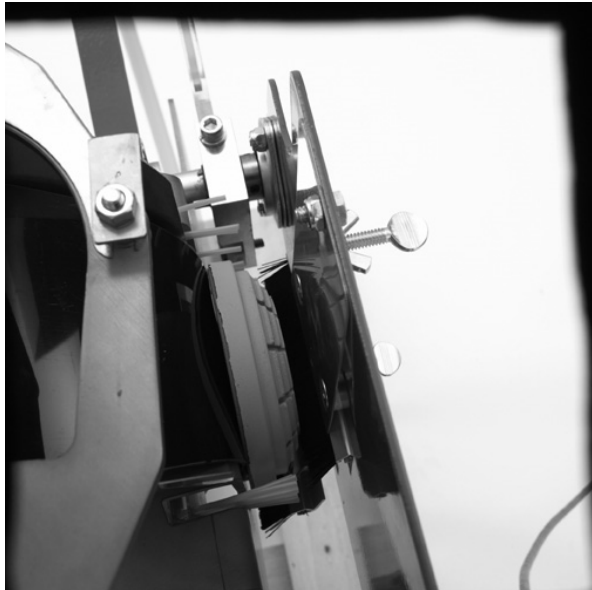

Illustration 6. Top View



Illustration 7. Target separation